

ABOUT GEOMETRIC DISTORTION. Anamorphic vertical compression lenses create a slight “barrel” shaped curvature especially at the edges of the image. **The amount of this distortion decreases as the projection distance is increased for a given screen size.** See the Image Geometry estimator in the Lens Selector at www.panamorph.com for approximate distortion to expect. Masking the edges of the image by the screen border makes this distortion much less noticeable especially for dramatic content.

CLEANING. Small amounts of dust and wipe marks are very noticeable on lens surfaces with a high brightness projection beam but typically will not impact the image as much as damage from excessive cleaning in pursuit of a "perfect" optical surface. Occasionally blowing off the lens surfaces with clean air is the best way to maintain long term performance. If there is any excessive residue or build-up then it is recommended that you clean the optics with professional lens cleaning supplies such as from a camera store while the lens is in front of the lit beam of the projector. This will allow you to quickly see if the cleaning process is causing any damage.

LIMITED WARRANTY. Panamorph, Inc. warrants this product against any change in performance or functionality for a period of twenty-four months from our ship date. During this period, a unit may be repaired or replaced, at the discretion of Panamorph, Inc., by returning it in its original packaging with a copy of your receipt. This warranty does not cover damage resultant from lack of prudent care, accident or misuse (including use with other products in ways not intended); any cosmetic damage not reported within 15 days of purchase; or any performance change caused by the environment in which it is used. All damages are limited to the cost of the product. This warranty is not transferable.

See www.panamorph.com for projector viewing mode settings with illustrations for various content when using either a 2.4:1 or 2.25:1 screen.

Panamorph[®]
We bring cinema home

DCR-S3

Direct Attach Cinema Format Conversion Lens

INSTALLATION GUIDE

(Phillips #2 screwdriver required)

For use only with the **Sony VPL-XW5000ES** projector
in ceiling-mounted orientation

Specifications: 6.3" (160mm) diam x 5.2" (132mm) depth. 2 lbs (0.9 kg). Allow 4" (102mm) in front of projector for installation. See back page for warranty.

IMPORTANT THEATER GUIDANCE

1. Projection screen should be **flat**, in the **2.25:1** aspect ratio for multimedia content, and with a **minimum 2.0" screen border**. A **2.4:1** screen may also be used for primarily 2.4:1 content with optical zoom adjustments or cropping for 16:9 content.
2. Projector lens center should be **between -4 and +18 inches from the top edge of the screen surface** (about +3 to +5 inches is ideal) and **horizontally centered** on the screen +/- 3 inches.
3. **Throw ratio** (throw distance divided by screen surface width) should be **at least 1.4:1**.
4. **Longer throw distances are encouraged to reduce edge distortion**. About 1.5" of screen border is needed to mask edge at 1.4:1 throw ratio. About 1.0" is needed at 1.6:1. At 2.0:1 throw ratio distortion is very difficult to see in any content.

DCR-S3 Installation Steps

- 1 INSTALL THE LENS RETAINER.** Remove the two front assembly screws and remove the retainer. Adjust the projector lens shift to vertically and horizontally center the projector lens. Squeeze the retainer and work it into the projector opening to nest into the inside rim of the projector housing with **prongs toward the ceiling** and the **top ridge aligned with the projector top-front rib**. Tighten the three retainer screws just enough to prevent rotation.



- 2 PREPARE THE PROJECTOR.** Adjust the projector roll, tilt and/or yaw so the projector test pattern lines are square to the screen edges. Adjust the vertical lens shift so the test pattern is centered on the screen. Now **show a 2.4:1 movie** instead of the test pattern. Set the Sony anamorphic lens menu setting to **1.32x** for a 2.25:1 screen or **1.24x** for a 2.4:1 screen. Set the Sony Aspect button on the remote to **V-Stretch**.

- 3 INSTALL THE DCR LENS.** After removing the rear DCR lens cover, install the DCR lens/mount assembly over the retainer prongs. Insert and tighten the two assembly screws to secure (**do not over tighten**). Remove the front protective film.

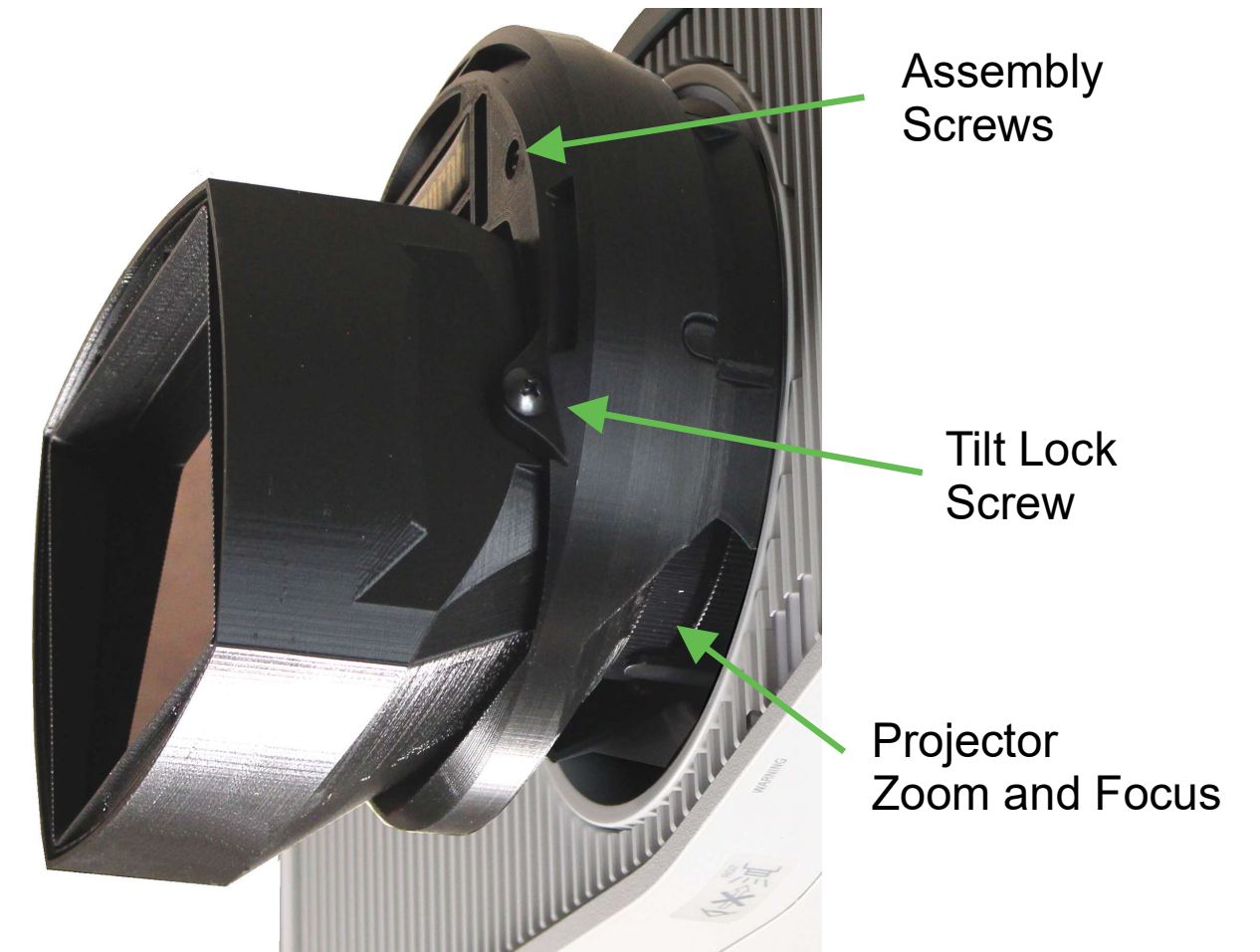

- 4 ADJUST THE LENS TILT AND PROJECTOR SHIFT.** Adjust the projector lens zoom to fill the width of the screen with the 2.4:1 movie. Tilt the DCR lens and adjust the projector vertical lens shift to make sure the beam is getting through the DCR lens to fill the screen. There is only a slight variation in vertical image height with this adjustment but experimentation may lead to the best image fit and geometry. Lock the DCR lens tilt by tightening the single Phillips tilt lock screw (**do not over tighten**).

- 5 DECIDE HOW TO WATCH 16:9 CONTENT** (including menus). Use the Sony "Aspect" button to select **Squeeze** (anamorphic to 1.24x) to watch 16:9 content in the screen center, or **Normal** to stretch 16:9 content to fill the entire screen width. On a 2.4:1 screen zoom down the image to avoid cropping the top and bottom.