

Panamorph

DC1 Specification Overview including ATH2 Automated Transport

Product Specifications	Dimensions	Weight
DC1 Lens Body	8.125" x 5.75" x 5.75"	10 lbs.
Shipping Specifications		
Lens Box and Contents:	12" x 10" x 9"	11 lbs.
DC1 System Shipping Box and Contents:	24" x 18" x 12"	34-36 lbs.
Designed and Assembled in the USA		

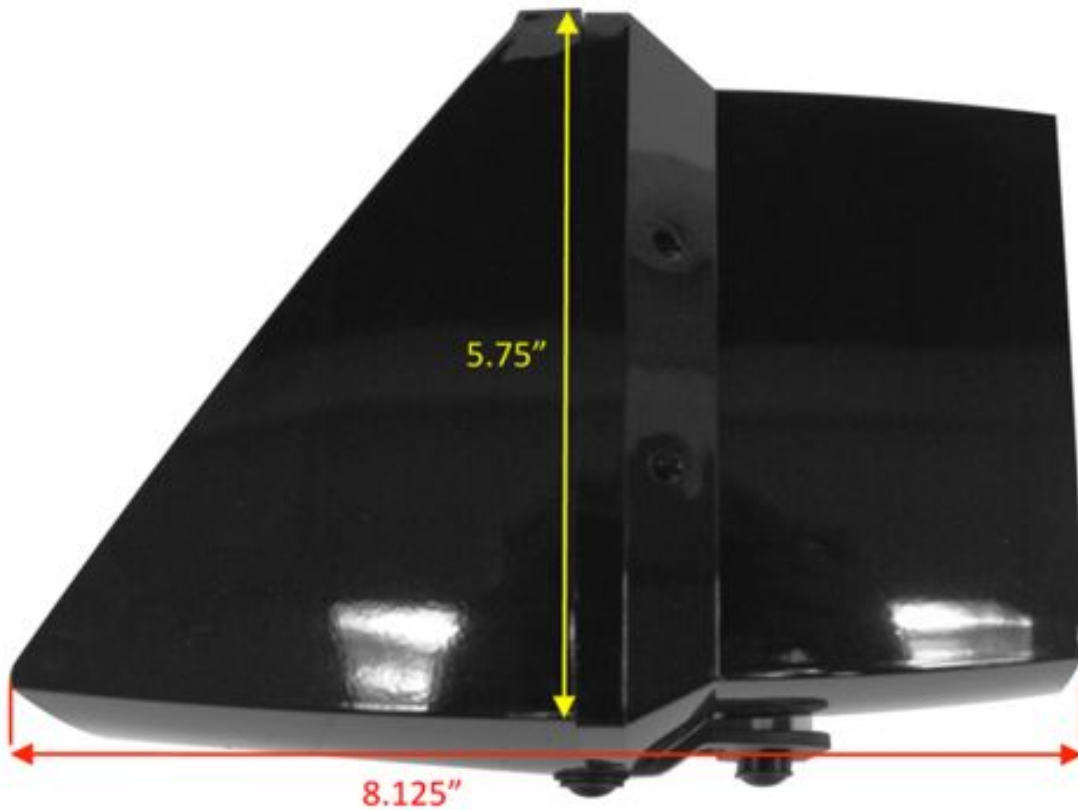

ATH2 Dimensions and Lens Bracket Height

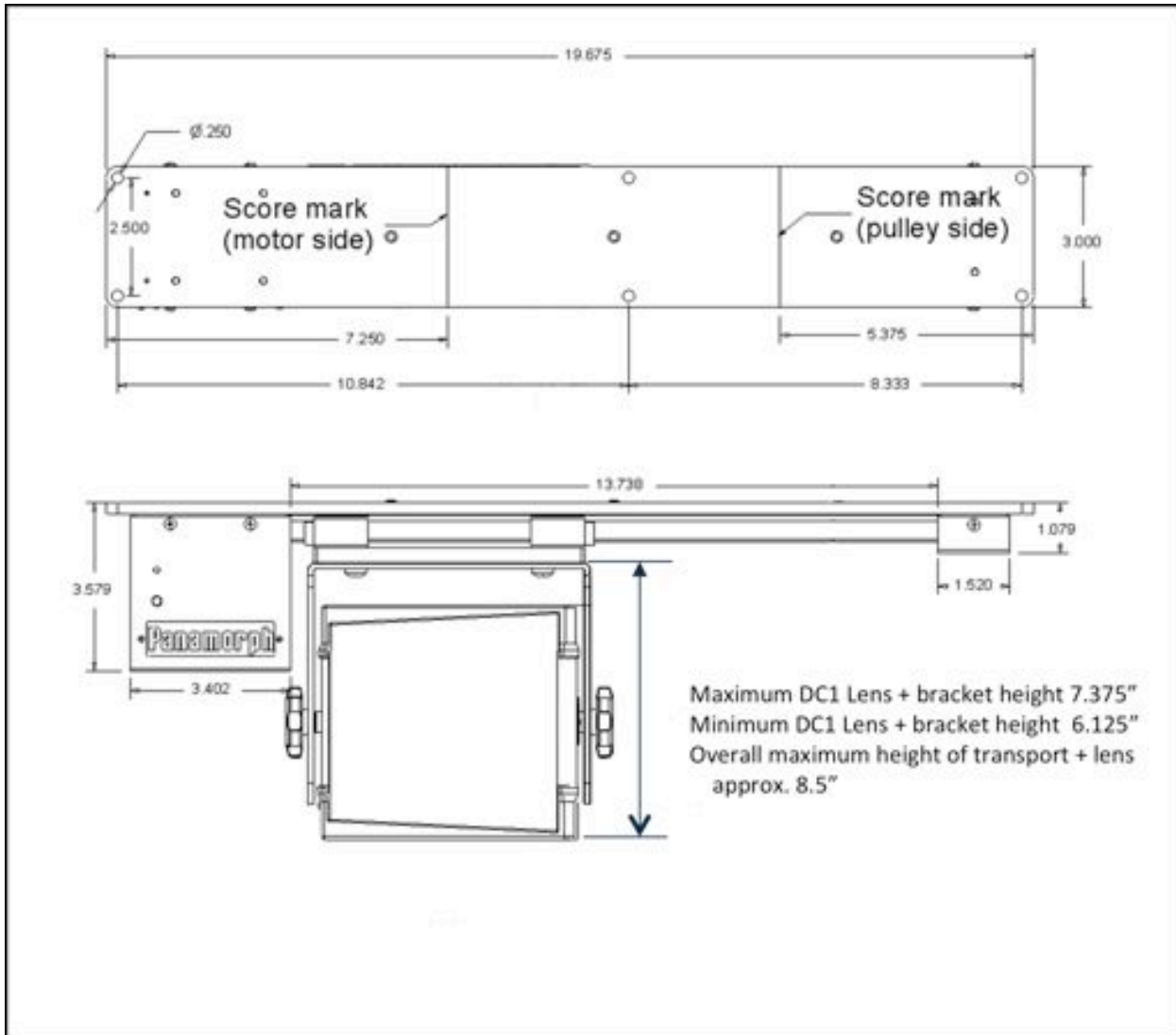

ATH2 Automated Transport

Electrical Characteristics

Model	ATH-2
Power supply	100-240VAC, 50-60 cycles
Power Supply Output	12V DC -.8A
Operating Voltage	9 -18V DC, .5-1.5A
Operating current draw	Avg : 650mA

Standby current draw	60mA
Trigger jacks	3.5 mm mono or stereo jack, 12V,tip positive, 20mA
Auxillary jack	2.5 mm stereo jack
Remote	3oz, IR emitter
IR Range	50ft from IR sensor
IR Carrier Frequency	38 kHz
Batteries	2 AAA
Certification	FCC, CE (ATH-2 motor drive unit) UL Class II (power supply only)
Design Life	Greater than 2,000,000 rail traversals

Physical characteristics

Weight	7 lbs.
Dimensions	See accompanying drawings